

Ex d Enclosure

Explosion / Flame proof



Application examples: Truck or tank filling



For custom single or repeating similar batches

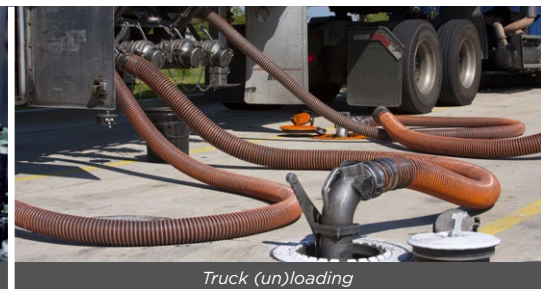

Truck (un)loading

This explosion / flame proof enclosure is specifically engineered to house our F-Series product range. Rugged and durable this enclosure will stand up to the most extreme conditions.

Dimensions

- Outside: 300 x 250 x 200mm (11.8" x 9.9" x 7.9") L x H x D.
- Inside: 225 x 175 x 167 (8.9" x 6.9" x 6.6") L x H x D.

Hazardous Area

- ATEX/IECEx certified: Gas: II 2 G Ex db IIB+H2 T5 Gb
Dust: II 2 D Ex tb IIIC T80°C Db
- Certificatenr.: CML 18ATEX1026X / IECEx CML 18.0021X

Features

- Sturdy aluminum IP66 casing.
- 4 x M20 nickel plated Ex d cable glands included.
- Both Ex d housing and cable glands available in Stainless Steel 316L.
- Terminal connector numbers are identical as shown in the manual of the product.
- Ambient temperature: -20°C to +40°C (-4°F to +104°F).
- Enclosure contains four 9mm (0.35") mounting holes.
- Weight is approximately 15 kg.
- Three buttons available, which will stand up to all conditions.

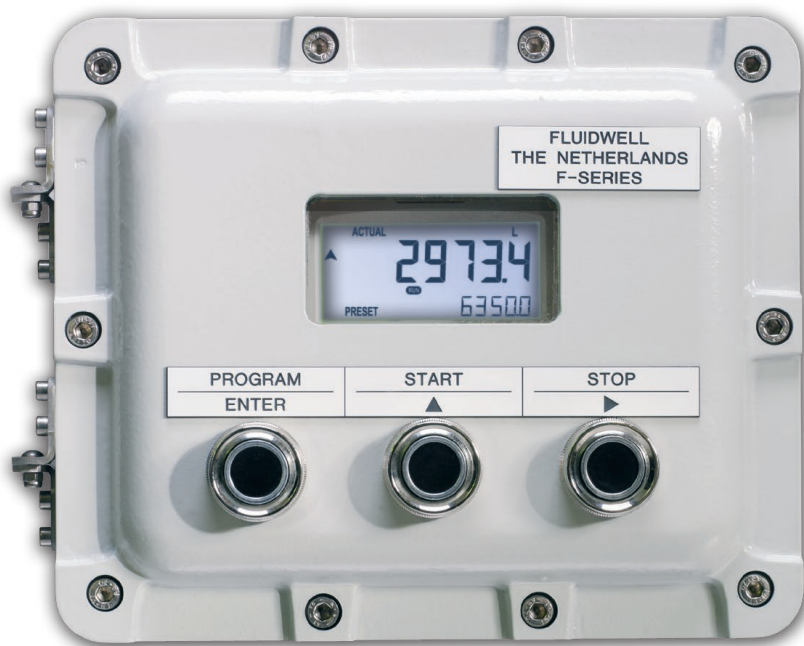

Mounting dimensions

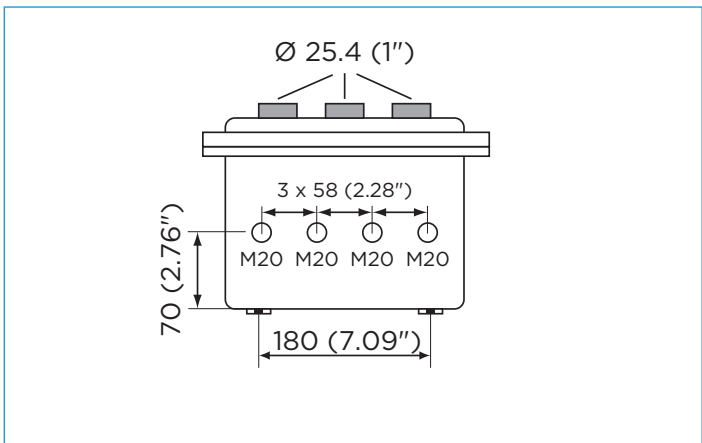
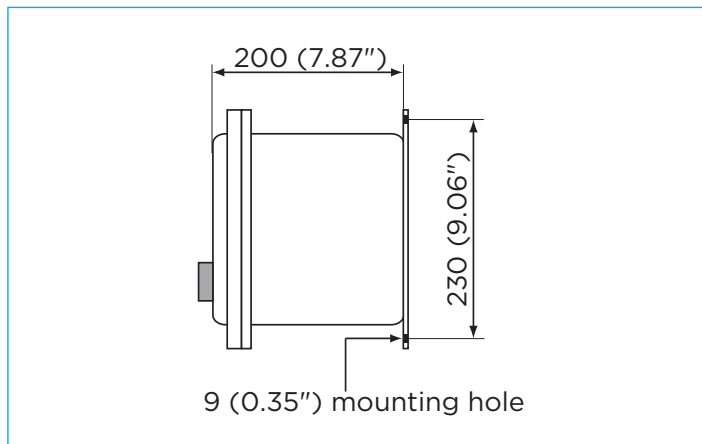
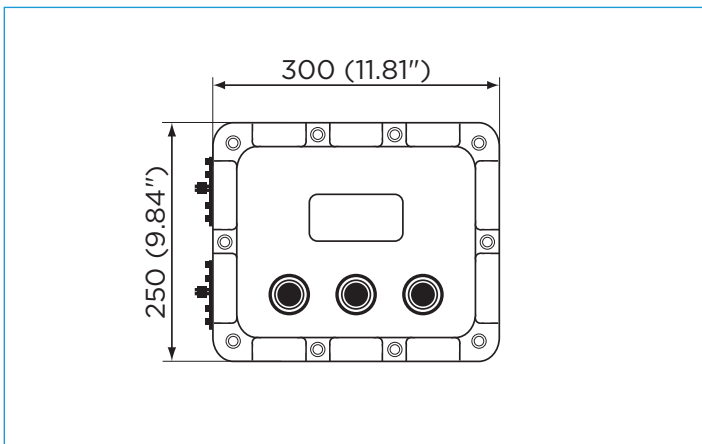

ATEX/IECEX certificates